

INTELLIGENT FIELD DEVICE

RIBMNW24B-BCAI

BACnet MS/TP Network Relay Device with Binary Output Set Point, One Binary Output + Override, Two Binary Inputs, One Analog Input, 24 Vac/dc Power Input, 2.75" Track Mount

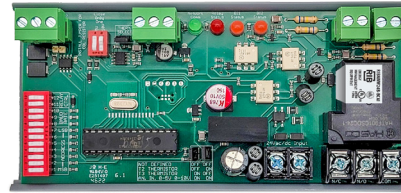
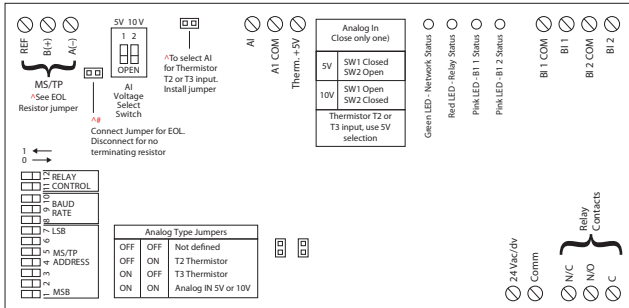

Code Version 1.5



SPECIFICATIONS

- # Relays & Contact Type:** One (1) SPDT Continuous Duty Coil
- Expected Relay Life:** 10 million cycles minimum mechanical
- Operating Temperature:** -30 to 140° F
- Humidity Range:** 5 to 95% (noncondensing)
- Operate Time:** 18ms
- Network Communication:** Green LED
- Relay Status:** Red LED On = Activated
- BI1 Status:** Pink LED On = Activated
- BI2 Status:** Pink LED On = Activated
- Dimensions:** 5.68"H x 2.75"W x 1.25"D1/1.75"D2
- Housing Detail:** See **Housing H** in housing guide for dimensions
- Origin:** Made of US and non-US parts
- Track Mount:** MT212-6 Mounting Track Provided
- Approvals:** UL Listed, UL916, C-UL, CE, RoHS, BTL Certified
- Gold Flash:** No
- Relay Override Switch:** DIP Switch Control (See Bulletin B1243)
- Network Media:** Twisted Pair 22-24AWG, shielded recommended
- Terminations:** Functional Devices product installed at both ends of the MS/TP network – Use 120 Ω end of line resistors. All other cases – Follow instructions from the device installed at the end of the MS/TP network.
- Polarity:** Network is polarity sensitive
- Baud Rate:** 9600, 19200, 38400, 57600, 76800, 115200 (DIP Switch Selectable - See Bulletin B1243)

- Contact Ratings:**
 - 20 Amp Resistive @ 277 Vac
 - 20 Amp Ballast @ 277 Vac
 - 16 Amp Electronic Ballast @ 277 Vac (N/O)
 - 10 Amp Tungsten @ 120 Vac (N/O)
 - 1110 VA Pilot Duty @ 277 Vac
 - 770 VA Pilot Duty @ 120 Vac
 - 2 HP @ 277 Vac
 - 1 HP @ 120 Vac

- Power Input Ratings:**
 - 81 mA @ 24 Vdc
 - 111 mA @ 24 Vac

• PIC Statement available on website.

Notes:

- For all versions, raw analog default settings are 0 and 1023 (real), respectively. Units default to 95 (no units). For Set Point Function settings, See Bulletin B1243
- **When connecting 24 Vac to both the RIB(s) and a half-wave device, damage to device can occur.**
 Option 1: Use separate transformers for each device.
 Option 2: Add diode between devices, (See Bulletin B1243 for diagram)

BACnet® Details:

- MS/TP Address & Baud Rate must be set prior to power up via DIP switches.
- Device ID will default to 277XXX where XXX is the MS/TP Address.

Examples:

MS/TP Address - 004 Device ID - 277004	MS/TP Address - 121 Device ID - 277121
---	---

- Device ID can be changed via network command. Once changed, it will no longer default to 277XXX. (MS/TP Address & Device ID must be unique.)
- This model utilizes: BO 1 (Relay output), BI 1 (Dry contact binary input), BI 2 (Dry contact binary input), AI 1 (Analog input), AV1 (Set Point), AV2 (Differential), BV1 (Function Enable), BV2 (Function Mode), BV3 (Function Status)
- Device Instance changed via Object Identifier Property of Device Object
- Thermistor Specifications:**
 - Thermistor Type 2 (T2) Precon 10 K @ 77°F (25°C) PN ST-R24, Model 24, (or equivalent.) Thermistor Type 3 (T3) Precon 10 K @ 77°F (25°C) Model 3, (or equivalent.) Thermistor not included.

- For both T2 and T3, MIN_PRES_VAL must be set to -36 (real value) and MAX_PRES_VAL must be set to 66.3 (real value) for Celcius. For Fahrenheit, MIN_PRES_VAL must be set to -32.8 (real value) and MAX_PRES_VAL must be set to 151.34 (real value).
- -35 to 10°C range in 1° steps / -31 to 50°F range in 1.8° steps
 10 to 32°C range in 0.1° steps / 50 to 90°F range in 0.18° steps
 32 to 100°C range in 1° steps / 90 to 212°F range in 1.8° steps

Set Point Function

for App. Version 1.5 or higher

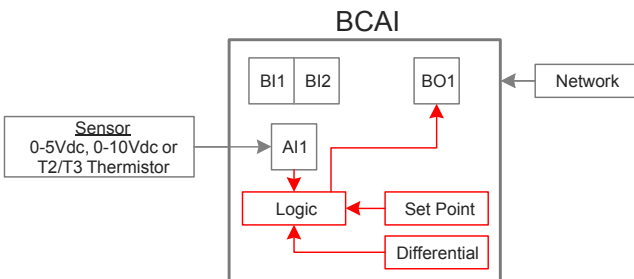

Set Point Function must be enabled via the Network for logic to execute. Once configured, the function will continue to operate even if communication is lost (see Bulletin B1243 for setup).