

10 AMP PILOT CONTROL TRACK MOUNT RELAYS

RIBM24C

Pilot Relay, 15 Amp SPDT, 24 Vac/dc Coil, 4.00" Track Mount

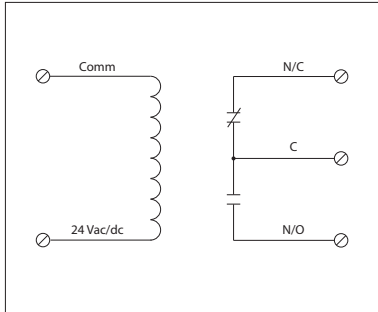

RIBM24S

Pilot Relay, 15 Amp SPST + Override, 24 Vac/dc Coil, 4.00" Track Mount

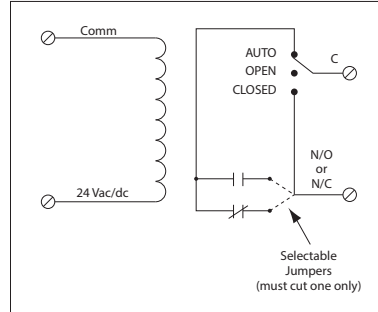

Cut for N/O

Cut for N/C

SPECIFICATIONS

- # Relays & Contact Type:** One (1) SPDT Continuous Duty Coil (RIBM24C)
One (1) SPST Continuous Duty Coil (RIBM24S)
- Expected Relay Life:** 10 million cycles minimum mechanical
- Operating Temperature:** -30 to 140° F
- Humidity Range:** 5 to 95% (noncondensing)
- Operate Time:** 6ms
- Relay Status:** LED On = Activated
- Dimensions:** 1.25"H x 4.00"W x 0.75"D1/1.25"D2 (RIBM24C)
1.25"H x 4.00"W x 1.25"D1/1.75"D2 (RIBM24S)
- Housing Detail:** See **Housing H** in housing guide for dimensions
- Origin:** Made of US and non-US parts
- Track Mount:** 4.000"
- Approvals:** UL Listed, UL916, C-UL, CE, RoHS
UL864, California State Fire Marshal
- Gold Flash:** No
- Override Switch:** No (RIBM24C) ; Yes (RIBM24S)

- Contact Ratings:**
15 Amp General Use @ 125 Vac
10 Amp General Use @ 277 Vac
10 Amp Resistive @ 30 Vdc (N/O)
7 Amp Resistive @ 30 Vdc (N/C)
1/2 HP @ 125 Vac
1 HP @ 250 Vac
1/4 HP @ 277 Vac
C300 Pilot Duty

- Coil Current:**
26 mA @ 20 Vac
31 mA @ 24 Vac
48 mA @ 35 Vac
14 mA @ 20 Vdc
18 mA @ 24 Vdc
28 mA @ 35 Vdc

- Coil Voltage Input:**
24 Vac/dc ; 50-60 Hz
Drop Out = 3 Vac / 3.8 Vdc
Pull In = 20 Vac / 20 Vdc

Notes:
Must cut appropriate jumper to select Normally Open or Normally Closed (RIBM24S)