

ENCLOSURE

MH3300 SERIES

Metal Housing, NEMA 1, 12.5" H x 12.5" W x 7.0" D

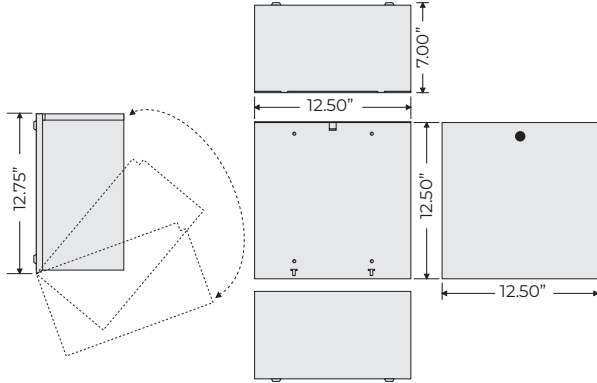

SPECIFICATIONS

Construction	18 Gauge Steel
Cover Type	Screw Down Cover
Approvals	UL Listed, C-UL, CE, RoHS
Origin	Made of US and non-US parts
Sub-Panels	SP3303: Polymetal - 11.33" H x 11.40" W SP3404: Perforated Steel - 11.33" H x 11.40" W

NOTE

Consult factory for custom colors on large orders.

SELECTION GUIDE

Model #	Enclosure	Cover Type	Sub-Panel
MH3300	MH3300	Vertical Lift Screw Down	-
MH3300K	MH3300K	Vertical Lift Key Latch	-
MH3303	MH3300	Vertical Lift Screw Down	SP3303
MH3304	MH3300	Vertical Lift Screw Down	SP3304
MH3303K	MH3300K	Vertical Lift Key Latch	SP3303
MH3304K	MH3300K	Vertical Lift Key Latch	SP3304