

# ESR-BCELTS Installation & Safety Instructions

## IMPORTANT SAFEGUARDS

When using electrical equipment, basic safety precautions should always be followed including the following:

### READ AND FOLLOW ALL SAFETY INSTRUCTIONS

#### ALL SERVICING SHOULD BE PERFORMED BY QUALIFIED PERSONNEL

- This product is intended for use with LED, Ballast, and Tungsten lighting loads ONLY.
- All wiring connections and mounting styles must be in accordance with the National Electrical Code (NEC), National Fire Protection Association (NFPA), National Electrical Safety Code, state and local codes, and any other regulations set forth by the local Authority Having Jurisdiction (AHJ).
- Per NFPA 70E, the use of Personal Protective Equipment (PPE) may be required. Check state and local codes.
- The load's operating voltage must be the same as the Emergency and Utility Power Input voltages.
- **WARNING:** More than one live circuit. Disconnect all sources of supply before servicing.
- This product enclosure must be grounded using steel, NEC approved conduit. To ensure electrical continuity, the enclosure coating shall be removed from contact surfaces, or the conduit shall be connected by means of fittings designed to make such removal unnecessary.
- To reduce the risk of electrical shock, fire, and injury to persons:
  1. Disconnect all sources of power before servicing,
  2. Mount this device in locations and at heights where it will not be readily accessible to tampering by unauthorized personnel,
  3. Do not mount near gas or electric heaters,
  4. Do not let any wires touch hot surfaces, and
  5. Do not use outdoors (NEMA 1 rating only)
- The use of accessory equipment not recommended by the manufacturer may cause an unsafe condition.
- Do not use this device for other than intended use.
- 120 – 277 Vac, 50/60 Hz, 16 A Max. Load
- Branch Circuit Emergency Lighting Transfer Switch
- Transfer initiates upon Normal Source Failure
- Normal to Alternate and Alternate to Normal Source transfers occur within 2 seconds.

## SAVE THESE INSTRUCTIONS

# Specifications

## ELECTRICAL SPECIFICATIONS

Normal Power Supply Voltage	120-277Vac
Normal Power Current Draw	7mA max
Normal Power Operating Frequency	50/60Hz
Emergency Power Supply Voltage	120-277Vac
Emergency Power Current Draw	9mA max
Emergency Power Operating Frequency	50/60Hz
Remote Test Input (Class 2, Dry Contact)	ESRTB or other switching method 1-2
Load Ratings	16A Magnetic Ballast @ 120-277V 16A Electronic Ballast @ 120-277V 16A Tungsten @ 120-277V

1. If not using the ESRTB Remote Test Button (sold separately), switching methods should be rated for at least 24Vdc. External voltage should not be supplied to this input. No specific current rating is required.
2. To maintain Class 2, a maximum of 45 total test inputs can be wired in parallel per ESRTB.

# Installations

## ALL INSTALLATIONS & WIRING SHOULD BE DONE BY QUALIFIED PERSONNEL

### Steps

1. Remove all sources of power.
2. Remove enclosure lid by loosening the 4 front screws, sliding the lid upwards, and carefully pull it forward.
3. There is a cable connecting the lid to the internal circuit board. This can be disconnected from the circuit board on the lid if necessary.
4. Make connections per one of the Application diagrams on Pages 5-8 of these instructions.
5. Tighten screw terminals to 10 in-lb. (1.1 Nm) max.
6. Terminal conductor gauge and quantity per Figure 1:
  - a. **A** Terminals - 12-24 AWG, two conductors maximum per position
  - b. **B** Terminals - 12-26 AWG, one conductor maximum per position
7. Make sure the enclosure is properly grounded using NEC approved conduit and bonding methods.
8. Put the lid back in place and tighten the lid screws down.
9. Apply all sources of power to the product.
10. Test the unit using one of the Test Procedures on Page 4.

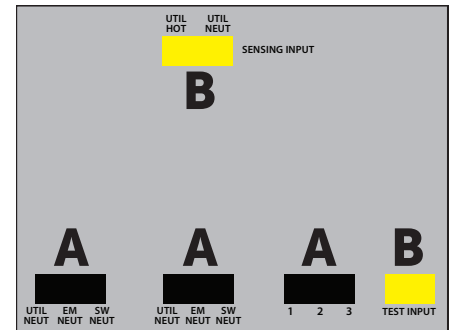

# Operation

This device will automatically transfer a lighting load from a Normal source to an Emergency source upon loss of Normal power. If Normal power is absent, the status of the load cannot be overridden. However, if the Normal power is present, the Emergency lighting load can be controlled by other means in order to use it as a Normal lighting load, depending on the wiring setup.

If it is not already being used for the Application wiring, the Auxiliary relay contacts can be used as status contacts. The contact between terminals #2 and #3 will be closed when Normal power is present and open when Normal power is lost. The contact between terminals #1 and #3 will be open when Normal power is present and closed when Normal power is lost.

# LED Definitions

## Blue LED (Fault Indicator)

This LED will flash when a fault is detected. To return the device to normal operation, the fault must be resolved and power to the unit must be cycled.

## Yellow LED (Load Power Indicator)

This LED indicates that there is power available for the connected Emergency lighting load. If the device is wired per one of the Application diagrams that utilizes a switching means, the Load may still be OFF. This LED will always be ON during normal operation. The only time this LED will turn OFF is during a transfer. Whether the transfer is initiated by a remote test input, pressing the integral test switch on the lid, or when Normal power is lost or returns, the Yellow LED will be OFF until the transfer completes.

## Red LED (Emergency Power Indicator)

This LED will be ON as long as Emergency power is connected to the unit.

## Green LED (Normal Power Indicator)

This LED will be ON as long as Normal power is connected to the unit.

CONDITION	ACTION
Red LED is OFF	<ul style="list-style-type: none"> <li>• Check Emergency Power Input wiring and voltage.</li> </ul>
Green LED is OFF	<ul style="list-style-type: none"> <li>• Check Normal Power Input wiring and voltage.</li> </ul>
Yellow LED is ON but Load is OFF	<ul style="list-style-type: none"> <li>• If using a Switch or Dimmer Control, make sure it is ON.</li> <li>• Check Load wiring.</li> <li>• Verify Load's operation voltage is the same as the Emergency Power Input Voltage.</li> <li>• Check bulbs and ballast.</li> <li>• Replace Unit.</li> </ul>
Load is ON but Yellow LED is OFF	<ul style="list-style-type: none"> <li>• Replace Unit.</li> </ul>
Load does not turn on when being testing	<ul style="list-style-type: none"> <li>• Check bulbs and ballast.</li> <li>• Check wiring connections if using a remote test option.</li> <li>• If using a Switch or Dimmer Control, make sure it is ON.</li> <li>• Replace Unit.</li> </ul>
Load will not turn OFF when Switch or Dimmer Control is turned OFF	<ul style="list-style-type: none"> <li>• Verify status of Utility Power Input.</li> <li>• Verify no test inputs are stuck closed.</li> </ul>
Blue LED is flashing	<ul style="list-style-type: none"> <li>• Cycle Emergency Power Input to the unit to reset the fault.</li> </ul>

# Maintenance

No routine maintenance is required for this device. Occasionally, this device should be tested to ensure that it works correctly in accordance with national and local codes.

# Application Testing

## Testing - Basic Transfer Application

Make connections per Basic Transfer Application diagram.  
Make sure Normal and Emergency sources are on.

1. The Red LED should be ON.
2. The Green LED should be ON.
3. The Yellow LED should be ON.
4. The Load should be ON.

### Local Test Button or Remote Test Button (ESRTB Sold Separately)

1. Press and hold Test Button on the enclosure lid.
2. The Green LED should be OFF.
3. The Yellow LED and Load will turn OFF while transfer happens.
4. After transfer, the Yellow LED and Load will turn back ON.
5. Release the "Test" button.
6. The Green LED should turn back ON.
7. The Yellow LED and Load will turn OFF while transfer happens.
8. After transfer, the Yellow LED and Load should turn back ON.

## Testing - 2, 3, or 4-Wire Dimming

Make connections per 2, 3, or 4-Wire Dimming Application diagram. Make sure Normal and Emergency sources are ON. Keep the switch or dimmer control OFF.

1. The Red LED should be ON.
2. The Green LED should be ON.
3. The Yellow LED should be ON.
4. The Load should be OFF.
5. The Dimmer Contacts should be :
  - \* #2 and #3 - Closed
  - \* #1 and #3 -Open

### Local Test Button or Remote Test Button (ESRTB Sold Separately)

1. Press and hold Test Button on the enclosure lid.
2. The Green LED should be OFF.
3. The Dimmer Contacts should be :
  - \* #2 and #3 - Open
  - \* #1 and #3 -Closed
4. The Yellow LED and Load will turn OFF while transfer happens.
5. After transfer, the Yellow LED and Load should turn back ON.
6. Release the "Test" button.
7. The Green LED should be ON.
8. The Yellow LED and Load will turn OFF while transfer happens.
9. After transfer, the Yellow LED should turn back ON.
10. The Dimmer Contacts should be :
  - \* #2 and #3 - Closed
  - \* #1 and #3 -Open

### Wall Switch or Controller Contact

1. Turn ON the Switch or Dimmer Control.
2. The connected Load should turn ON.
3. Turn OFF the Switch or Dimmer Control.
4. Emergency light should turn OFF.

## Testing - Bypass Application

Make connections per Bypass Application diagram.  
Make sure Normal and Emergency sources are ON.  
Make sure the Control Input(wall switch, dimmer, etc.) being bypassed is ON.

1. The Red LED should be ON.
2. The Green LED should be ON.
3. The Yellow LED should be ON.
4. The Load should be ON.
5. Turn the Control Input OFF.
6. Load should be OFF.
7. Remove the Normal Sources of Power from the unit.
8. The Load should turn ON after the unit completes the transfer.
9. Apply the Normal source of power back to the unit.

### Local Test Button or Remote Test Button (ESRTB Sold Separately)

1. Press and hold Test Button on the enclosure lid.
2. The Green LED should be OFF.
3. The Yellow LED will turn OFF while transfer happens.
4. After transfer, the Yellow LED and Load will turn back ON.
5. Release the "Test" button.
6. The Green LED should turn back ON.
7. The Yellow LED and Load will turn OFF while transfer happens.
8. After transfer, the Yellow LED should turn back ON and the Load should be OFF.

## Testing - Bypass and Dimming Applications

Make connections per Bypass and Dimming Application diagram. Make sure Normal and Emergency sources are on.  
Make sure the Control Input(wall switch, dimmer, etc.) being bypassed is ON.

1. The Red LED should be ON.
2. The Green LED should be ON.
3. The Yellow LED should be ON.
4. The Load should be ON and Dimmed to the level set by the control.
5. Turn the Control Input OFF.
6. Load should be OFF.
7. Remove the Normal Sources of Power from the unit.
8. The Load should turn ON at full brightness after the unit completes the transfer.
9. Apply the Normal source of power back to the unit.

### Local Test Button or Remote Test Button (ESRTB Sold Separately)

1. Press and hold Test Button on the enclosure lid.
2. The Green LED should be OFF.
3. The Yellow LED will turn OFF while transfer happens.
4. After transfer, the Yellow LED and Load will turn back ON.
5. Release the "Test" button.
6. The Green LED should turn back ON.
7. The Yellow LED and Load will turn OFF while transfer happens.
8. After transfer, the Yellow LED should turn back ON and the Load should be OFF.

# Application Diagrams

## UL1008 - BASIC TRANSFER APPLICATION

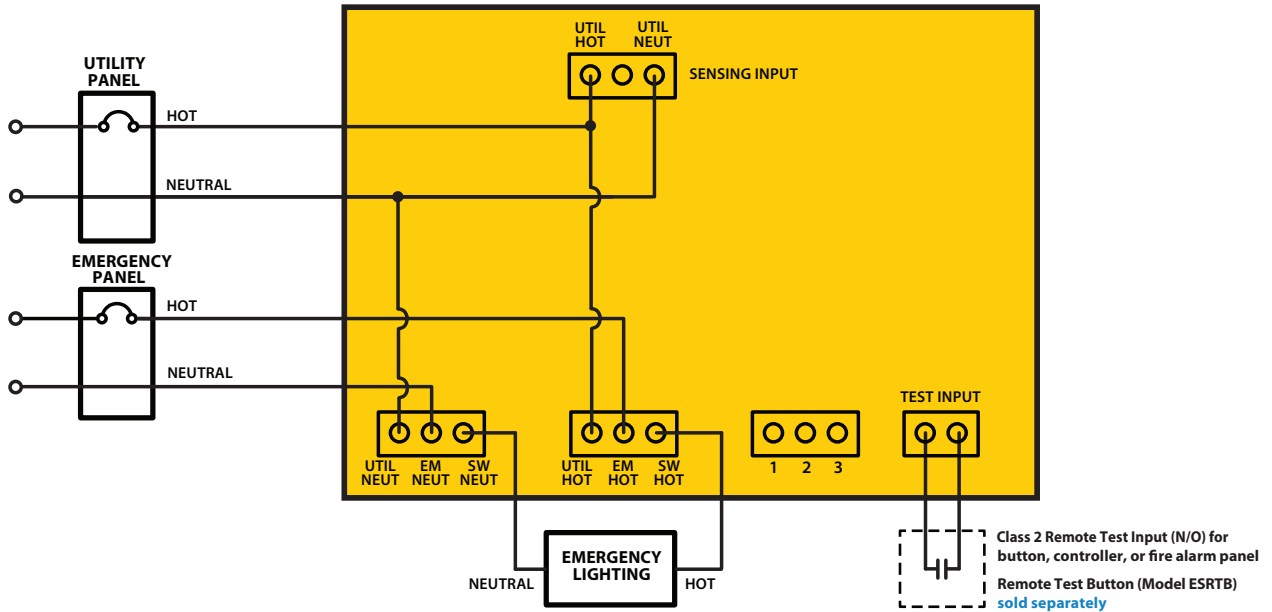

## UL1008 - SWITCH OR 2-WIRE DIMMING APPLICATION

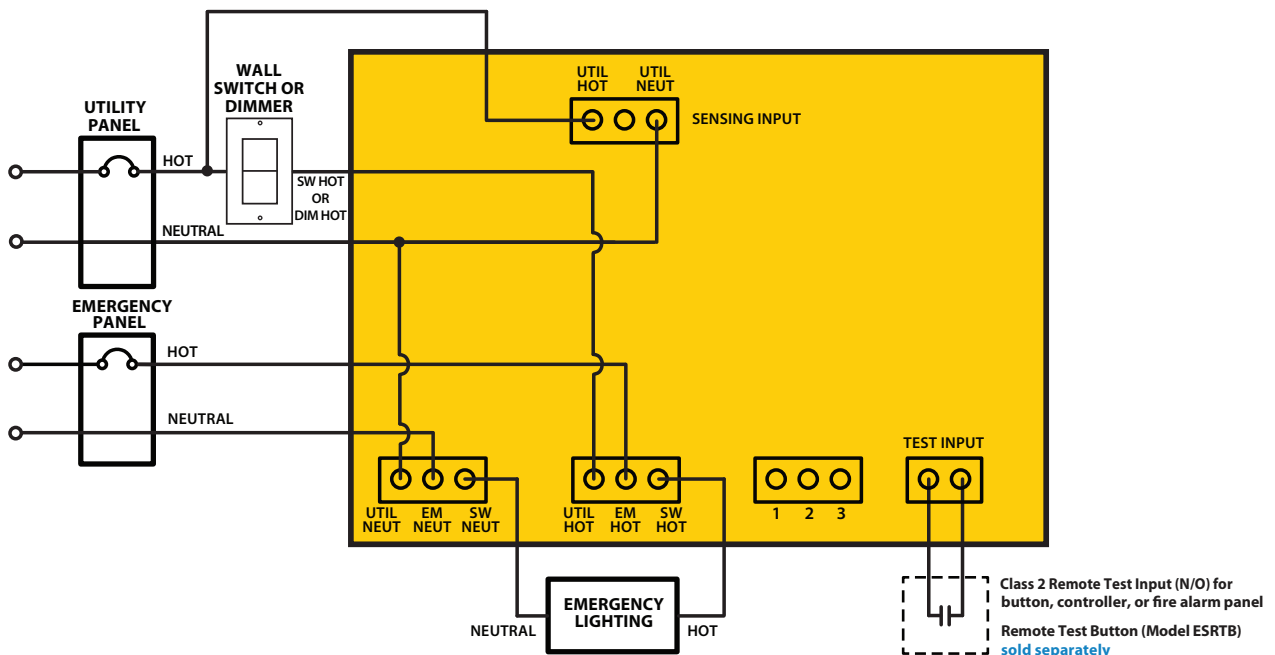

# Application Diagrams

## UL1008 - 3-WIRE DIMMING APPLICATION

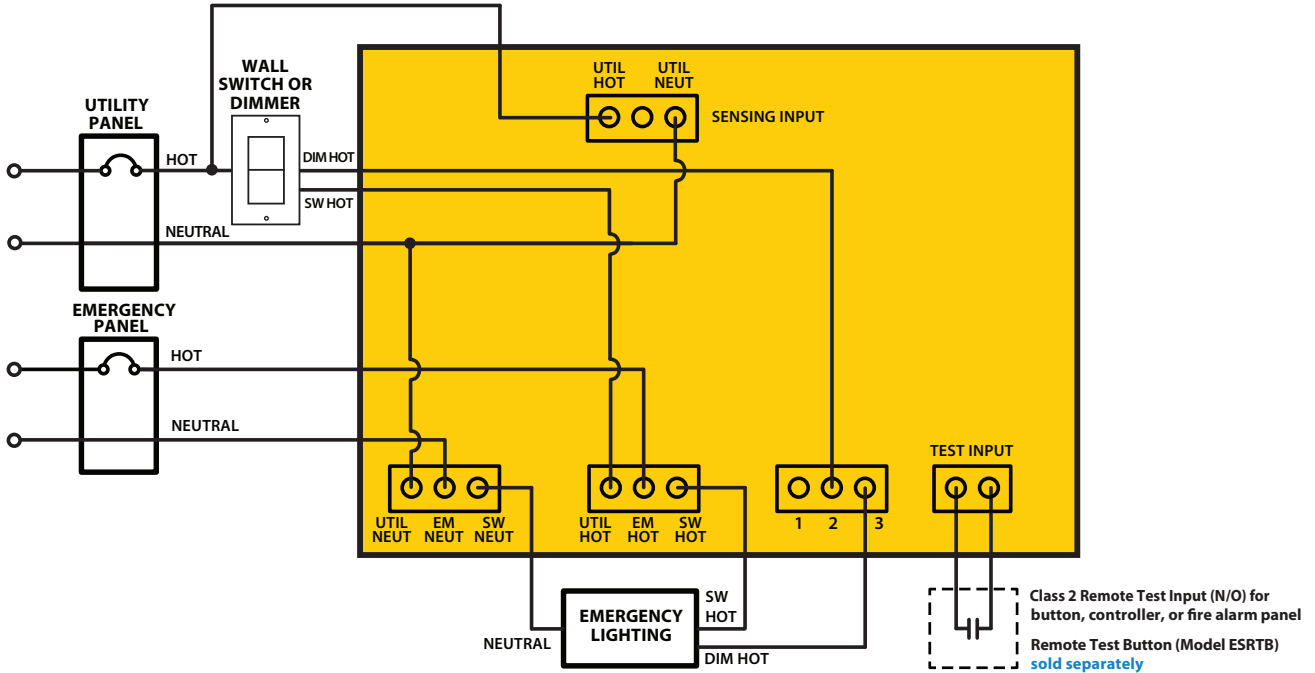

## UL1008 - 4-WIRE (0-10V) DIMMING APPLICATION

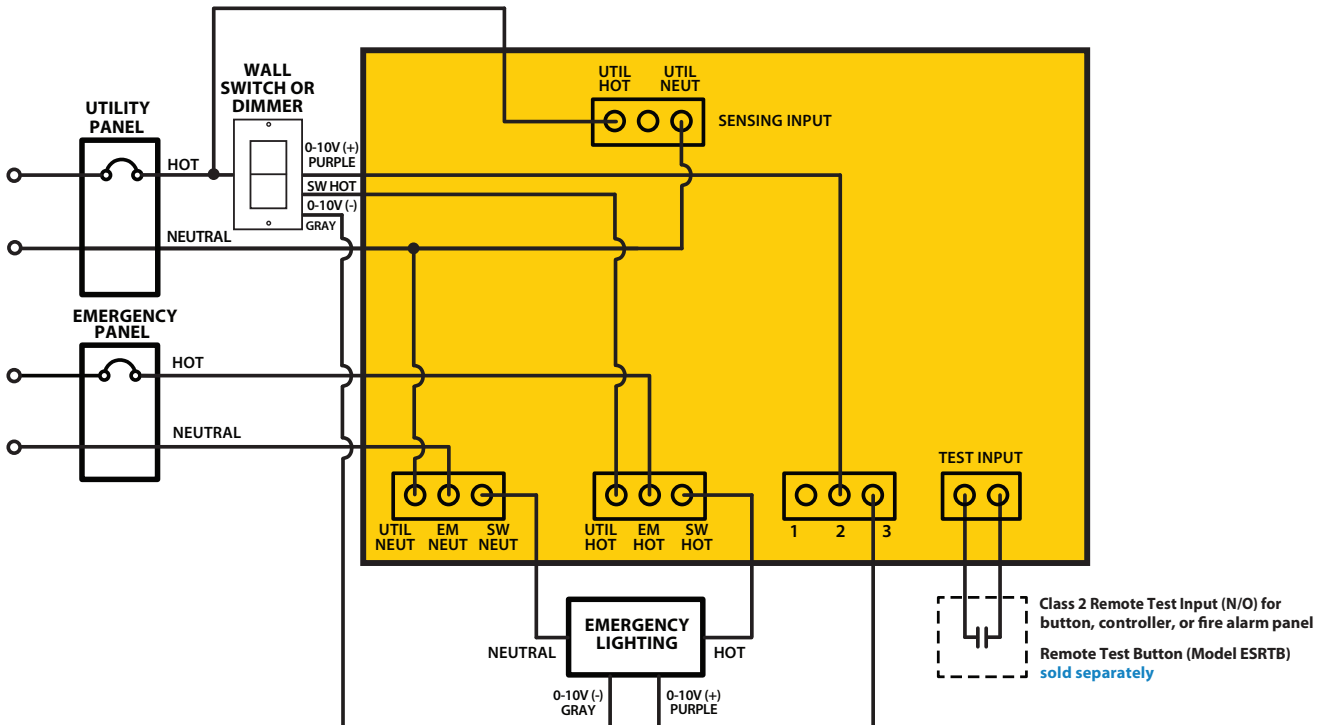

# Application Diagrams

## UL1008 - 4-WIRE (DALI) DIMMING APPLICATION

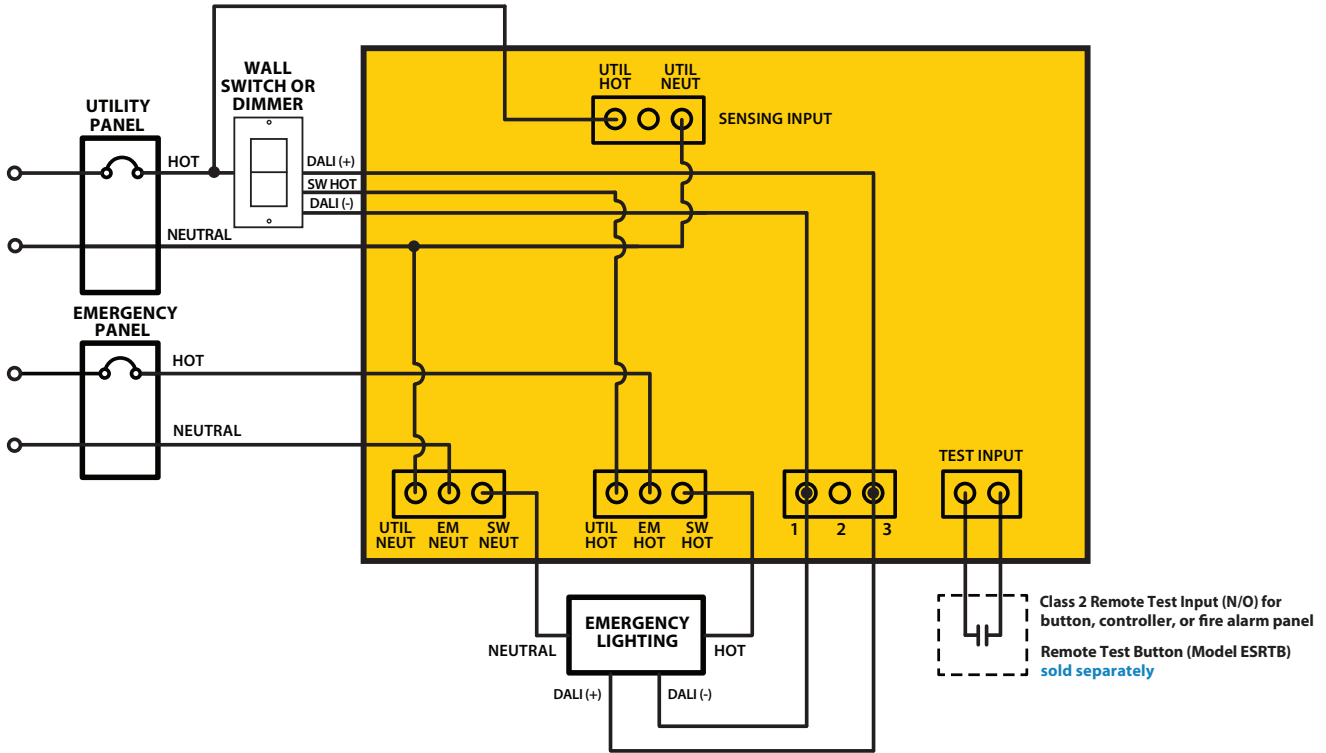

## UL924 - BYPASS APPLICATION

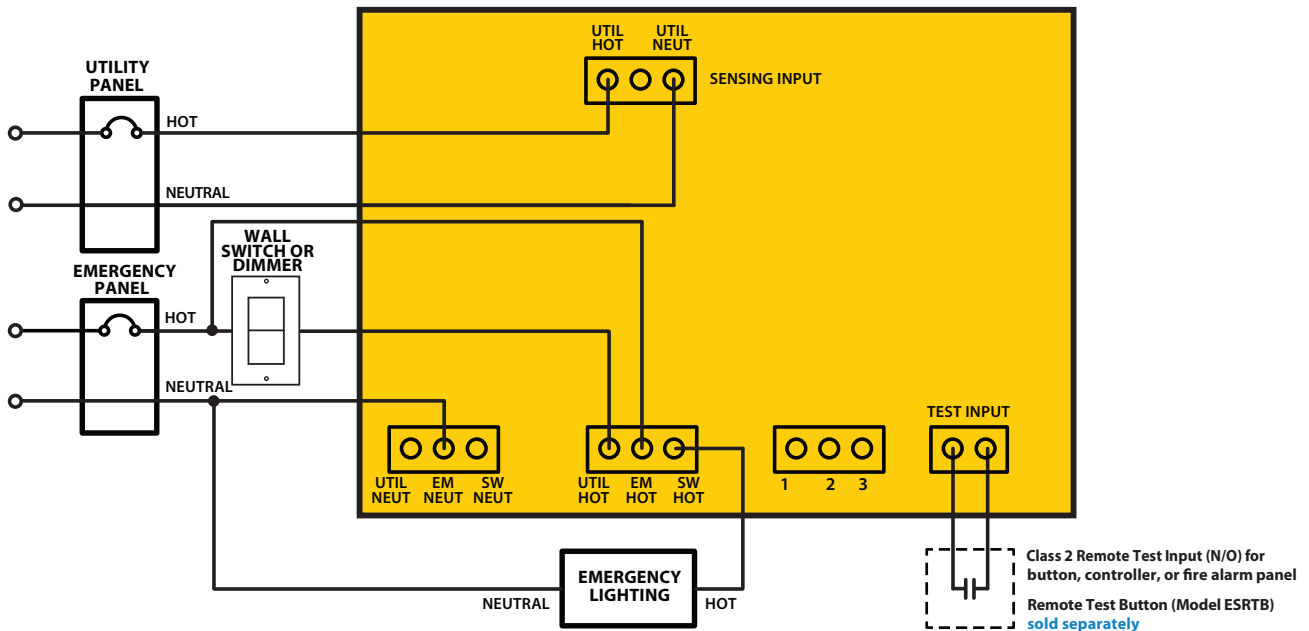

# Application Diagrams

## UL924 - BYPASS WITH 0-10V APPLICATION

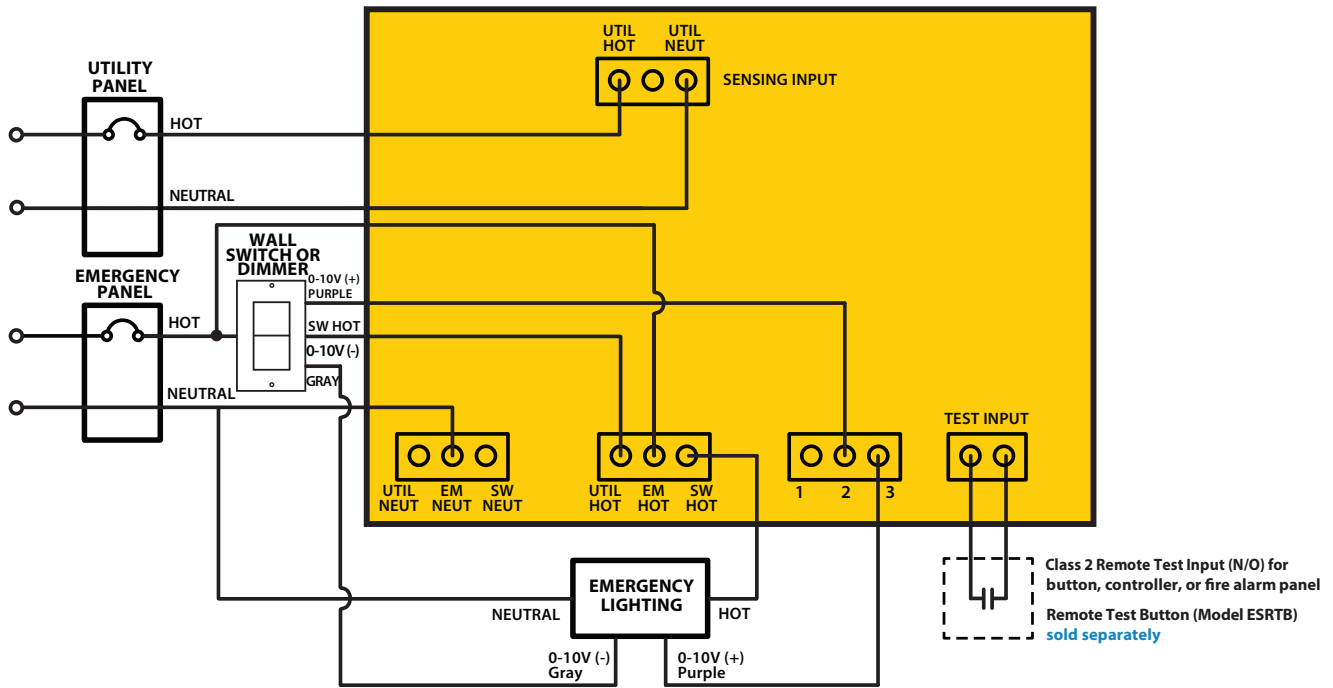

## UL924 - BYPASS WITH DALI DIMMING APPLICATION

